

WPCN381U

Legacy-Reduced SuperI/O with Fast Infrared Port, Two Serial Ports and GPIOs

General Description

The WPCN381U, a member of the Winbond LPC SuperI/O family, is targeted for legacy-reduced ultra-light portable applications. The WPCN381U is PC2001 and ACPI compliant, and features a Fast Infrared port (FIR, IrDA 1.1 compliant), two Serial Ports and General-Purpose Input/Output (GPIO) support for a total of 11 ports.

The WPCN381U is a “no-frills” solution for the new generation of notebook systems, providing just the essential functions.

Outstanding Features

- Pin and software compatible with the Winbond 87381
- Fast Infrared Port (FIR)
- Two Serial Ports
- LPC bus interface, based on Intel's *LPC Interface Specification* Revision 1.1, August 2002 (supports $\overline{\text{CLKRUN}}$ and $\overline{\text{LPCPD}}$ signals)
- PC2001 and ACPI Revision 3.0 compliant
- 11 GPIO ports, including 6 with IRQ assertion capability
- Two testability modes (XOR Tree and TRI-STATE[®] device pins).
- 5V tolerant and back-drive protected pins (except LPC bus pins)
- 48-pin LQFP package

System Block Diagram

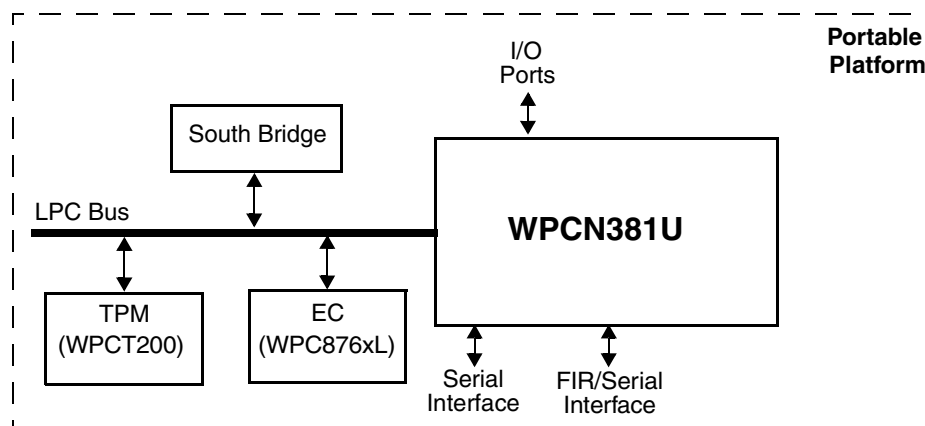

Features

- Fast Infrared Port (FIR)
 - Software compatible with the 16550A and the 16450
 - Shadow register support for write-only bit monitoring
 - FIR IrDA 1.1 compliant
 - HP-SIR
 - ASK-IR option of SHARP-IR
 - DASK-IR option of SHARP-IR
 - Consumer Remote Control supports RC-5, RC-6, NEC, RCA and RECS 80
 - DMA support: one or two channels
- Two Serial Ports (SP1 and SP2)
 - SP2 can be used only when FIR is not needed
 - Software compatible with the 16550A and the 16450
 - Shadow register support for write-only bit monitoring
 - UART data rates up to 1.5 Mbaud
- 11 General-Purpose I/O (GPIO) Ports
 - Supports IRQ assertion
 - Programmable drive type for each output pin (open-drain, push-pull or output disable)
 - Programmable option for internal pull-up resistor on each input pin
 - Output lock option
 - Input debounce mechanism
- LPC System Interface
 - 8-bit I/O cycles
 - $\overline{\text{LPCPD}}$ and $\overline{\text{CLKRUN}}$ support
 - Implements PCI mobile design guide recommendation (*PCI Mobile Design Guide 1.1, Dec. 18, 1998*)
- PC2001 and ACPI 3.0 Compliant
 - PnP Configuration Register structure
 - Flexible resource allocation for all logical devices
 - Relocatable base address
 - 15 IRQ routing options
 - Optional 8-bit DMA channels (where applicable) selected from four possible DMA channels
- Clock Sources
 - 14.318 MHz or 48 MHz clock input
 - LPC clock, 0 or 30 MHz to 33 MHz
- Strap Configuration
 - Base Address (BADDR) strap to determine the base address of the Index-Data register pair
 - Strap Inputs to select testability mode
- Power Supply
 - 3.3V supply operation
 - All pins are 5V tolerant, except LPC bus pins
 - All pins are back-drive protected, except LPC bus pins
- Testability
 - XOR Tree
 - TRI-STATE device pins

Internal Block Diagram

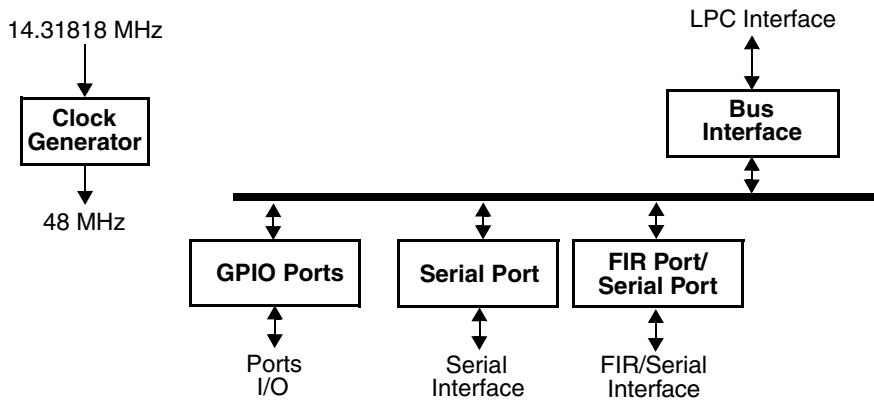

Physical Dimensions

All dimensions are in millimeters

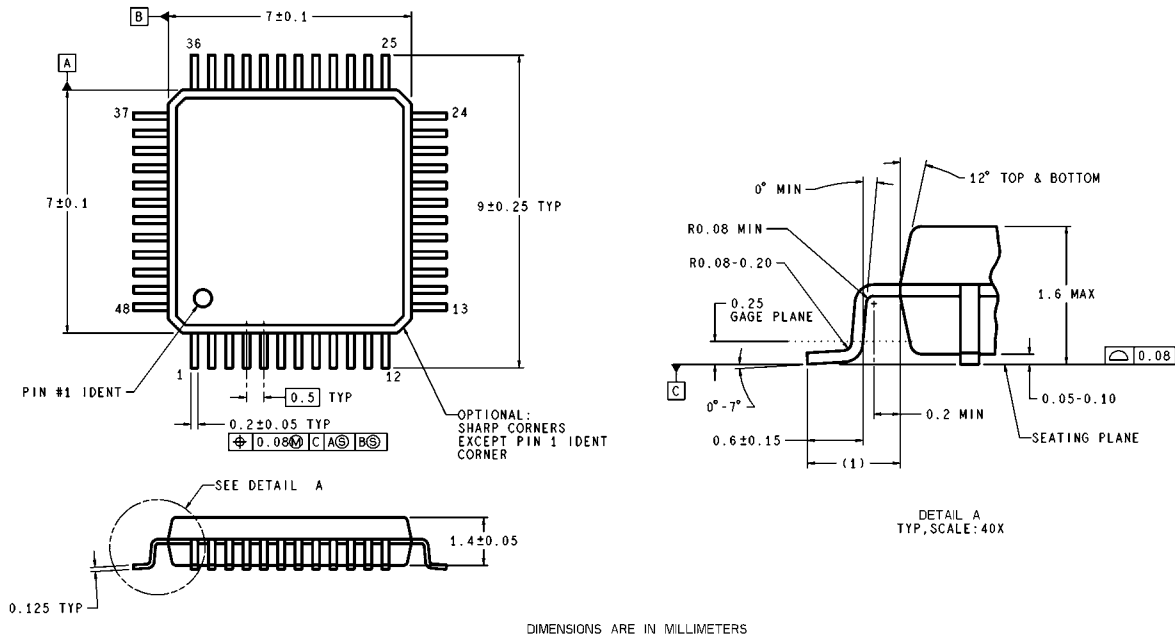

VBH46A (Rev D)

48-Pin Low-Profile Plastic Quad Flatpack (LQFP)
Order Number WPCN381U_0DG
(Replace “_” with chip revision: A, B, and so on)

Important Notice

Winbond products are not designed, intended, authorized or warranted for use as components in systems or equipment intended for surgical implantation, atomic energy control instruments, airplane or spaceship instruments, transportation instruments, traffic signal instruments, combustion control instruments, or for other applications intended to support or sustain life. Furthermore, Winbond products are not intended for applications wherein failure of Winbond products could result or lead to a situation wherein personal injury, death or severe property or environmental damage could occur.

Winbond customers using or selling these products for use in such applications do so at their own risk and agree to fully indemnify Winbond for any damages resulting from such improper use or sales.

Headquarters
 No. 4, Creation Rd. III,
 Science-Based Industrial Park,
 Hsinchu, Taiwan
 TEL: 886-3-5770066
 FAX: 886-3-5665577
<http://www.winbond.com.tw/>

Winbond Electronics Corporation America
 2727 North First Street, San Jose,
 CA 95134, U.S.A.
 TEL: 1-408-9436666
 FAX: 1-408-5441798

Winbond Electronics (Shanghai) Ltd.
 27F, 2299 Yan An W. Rd. Shanghai,
 200336 China
 TEL: 86-21-62365999
 FAX: 86-21-62365998

Taipei Office
 9F, No.480, Rueiguang Rd.,
 Neihu District, Taipei, 114,
 Taiwan, R.O.C.
 TEL: 886-2-8177-7168
 FAX: 886-2-8751-3579

Winbond Electronics Corporation Japan
 7F Daini-ueno BLDG, 3-7-18
 Shinyokohama Kohoku-ku,
 Yokohama, 222-0033
 TEL: 81-45-4781881
 FAX: 81-45-4781800

Winbond Electronics (H.K.) Ltd.
 Unit 9-15, 22F, Millennium City,
 No. 378 Kwun Tong Rd.,
 Kowloon, Hong Kong
 TEL: 852-27513100
 FAX: 852-27552064

For Advanced PC Product Line information contact: APC.Support@winbond.com

Please note that all data and specifications are subject to change without notice.
 All the trademarks of products and companies mentioned in this datasheet belong to their respective owners.