

Total Harmonic Distortion on WinPot WMS7202

AN-WP03003

Introduction

This application note provides an examination of the Total Harmonic Distortion (THD) on WinPot WMS7202 family of dual channel digital controlled potentiometer. The THD is a means of indication of nonlinear distortion on the signal. The THD can cause smeared and unclear audio signals. The THD can also raise baseline noise level, which mask out low-level audio information.

Total Harmonic Distortion Test

The THD is measured by monitoring the output spectrum via an audio analyzer and observing the values of the second, third, fourth, etc harmonics with respect to the amplitude of the fundamental signal. The value is expressed as a ratio in percentage. Each component is combined in a root sum square fashion:

$$THD = \left(\frac{\sqrt{e_2^2 + e_3^2 + e_4^2 + \dots + e_n^2}}{e_{in}} \right) \times 100\%$$

Where:

e_{in} = Input signal level

e_n = Nth Harmonic level, $N = 2, 3, \dots$

The THD is measured by applying a fundamental signal of 1kHz, 1Vrms sine wave to the input, VA, and the output signal is measured from VW with a Panasonic VP-7723A Audio Analyzer. Other conditions are: VB is connected to GND, the Wiper is set to Half Scale, output buffer is off, VCC = 5V and VSS = 0V. Besides, input to resistor, VA, and output of resistor, VW, are buffered with low noise OpAmps. The OpAmps have separate power supply from the DUT. All power supplies are decoupled to GND in order to reduce any power supply noises.

Diagram for the THD test.

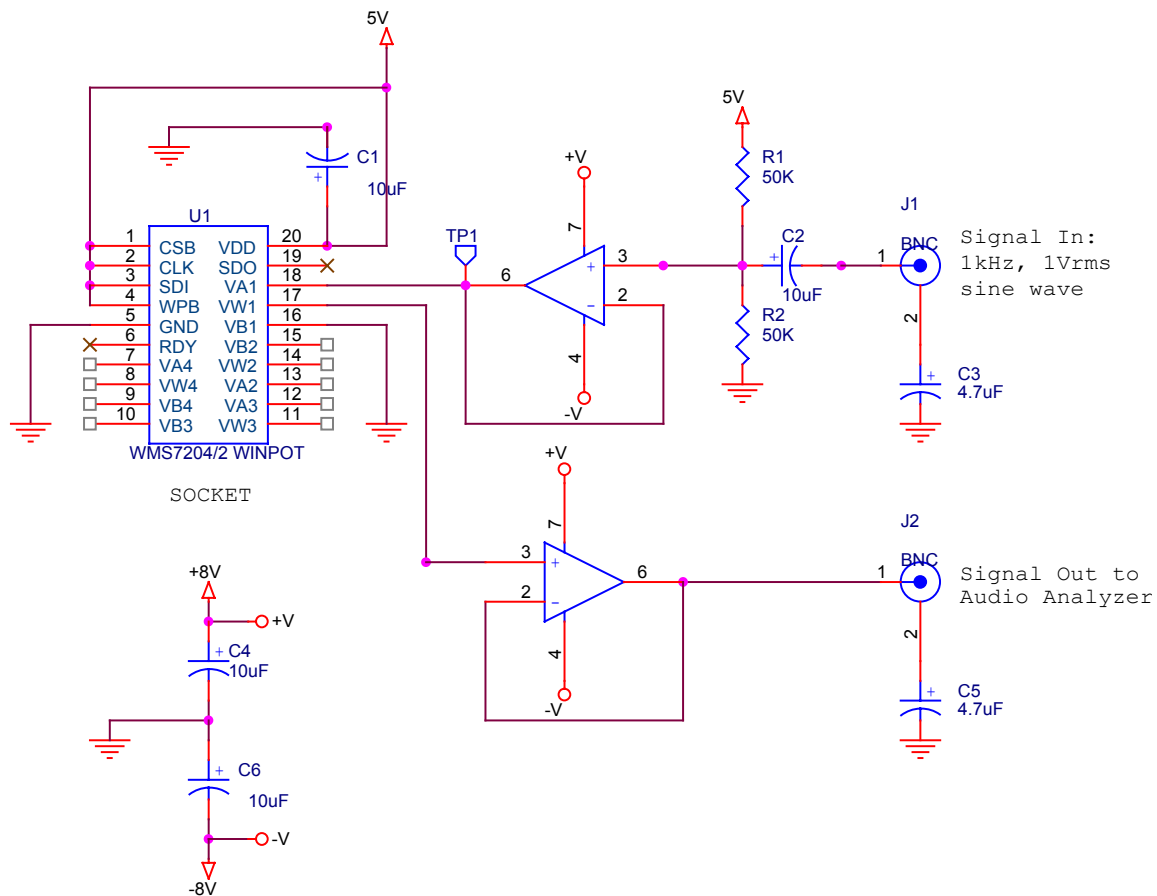

OpAmps are OPA277s, R1 and R2 provide 2.5Vdc offset for the input signal ensuring that it stays within 0v and 5V.

The THD is checked at VA, TP1, for purity of signal into the resistor.

Here THD = 0.0004%, 2 orders of magnitude better than the signal out of the resistor (see results table below).

Results:

	10K		50K		100K
Sample	THD/%	Sample	THD/%	Sample	THD/%
A	0.052	B	0.045	B	0.044
C	0.052	C	0.047	C	0.045
D	0.052	D	0.045	D	0.045
E	0.054	E	0.044	E	0.045

The results indicate that the THD is fairly constant across samples. Also, the THD of the 50K and 100K devices are better than that of the 10K device.