

8-Pin SOIC 208-mil (Package Code S)

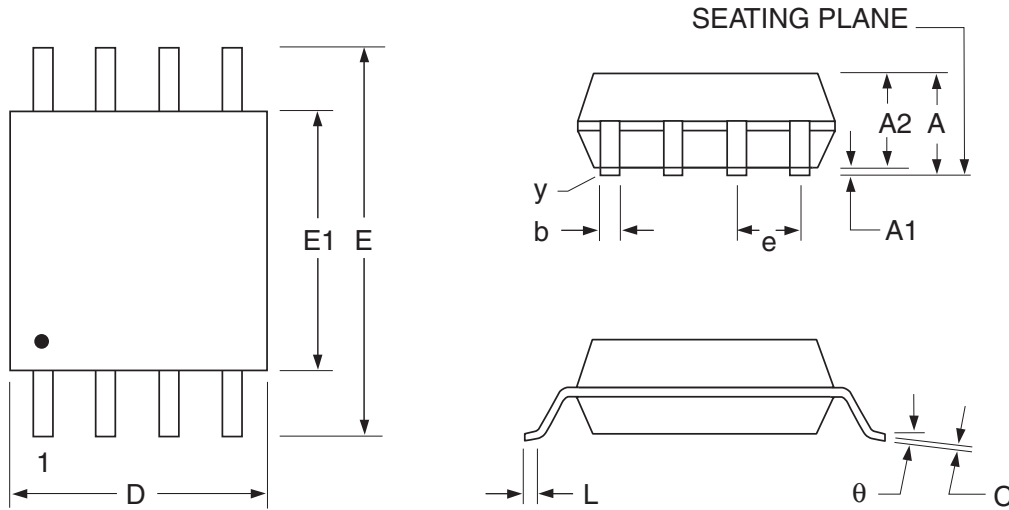

Package Dimensions

Symbol	Millimeters		Inches	
	Min	Max	Min	Max
A	1.75	2.16	0.069	0.085
A1	0.05	0.25	0.002	0.010
A2	1.70	1.91	0.067	0.075
b	0.35	0.48	0.014	0.019
C	0.19	0.25	0.007	0.010
D	5.18	5.38	0.204	0.212
E	7.70	8.10	0.303	0.319
E1	5.18	5.38	0.204	0.212
e	1.27BSC		0.050 BSC	
L	0.50	0.80	0.020	0.031
θ	0°	8°	0°	8°
y	0.10		0.004	

Notes:

1. Controlling dimensions: inches, unless otherwise specified.
2. BSC = Basic lead spacing between centers.
3. Dimensions D and E1 do not include mold flash protrusions and should be measured from the bottom of the package.
4. Formed leads shall be planar with respect to one another within .0004 inches at the seating plane.